

**1st Semester
SAC
Physics
Problems**

SAC102

The set includes problems involving translational kinetic energy, the gravitational potential energy of objects near the surface of the earth, and the principle of the conservation of mechanical energy. Unless otherwise specified in the problem the given symbols are to be considered known. Solve for the sought quantity in terms of the given symbols. Express your answer by writing the symbol for the sought quantity all by itself on the left side of an equation, and, on the right side of that same equation, writing an algebraic expression in which the symbols representing quantities are all given symbols.

1) A rock is thrown straight upward. It leaves the throwers hand at a height h above the surface of the earth with a speed v . How high above the surface of the earth does the rock go? Neglect air resistance.

2) A pebble of mass m is shot, over flat level ground, from a sling shot. The pebble is shot at an angle θ above the horizontal where θ is greater than 0° but less than 90° . The pebble leaves the sling shot at ground level. At the highest point in its trajectory, the pebble is traveling at speed v' at height h above the ground. At what speed did the pebble leave the sling shot? Neglect air resistance.

3) A bullet of mass m is fired straight upward. It leaves the muzzle of the gun with a speed v . The bullet goes straight up and comes straight back down. By the time it again arrives at the point where it left the muzzle of the gun, it has a velocity v' which is less than v . How much mechanical energy is lost by the bullet on its round trip (which starts and ends at the point where the bullet leaves the muzzle of the gun).

4) A ball of mass m is hanging by a string of negligible mass. The ball is pulled to one side, a distance such that the ball is raised through a height h . The ball is released from rest. It swings away from the point of release. Find the speed of the ball at the bottom of its swing.

5) Depicted at right is a metal ball of mass m and negligible diameter. The ball is suspended from a fixed support by a massless string. The string is just barely in contact with a cylinder of radius r that is fixed in position so that it can neither move nor turn. A person pulls the ball up and away from the cylinder until the string is horizontal. The person releases the ball from rest. It swings down and then around the cylinder as the string wraps itself around the cylinder. How fast is the ball going when it is at the highest position it reaches subsequent to the string starting to wrap itself around the cylinder?

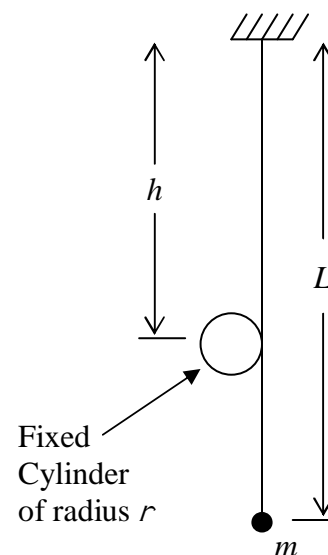

SAC102

6) A uniform block of mass m has the shape of a cube of edge length b . A flat straight horizontal board of length L and width w has two lines marked on the top face of it. Each line extends across the width of the board and is perpendicular to the length of the board. The lines are a distance d apart from each other. The top face of the board is so slippery that we can consider it to be frictionless. A person lifts and props up one end of the board high enough so that the board makes an angle θ with the horizontal (while the two drawn lines are still horizontal). The board is fixed in place in this orientation. Then the person brings one side of the block into contact with the top face of the board and positions the block so that the lowest edge of the block is aligned with the higher drawn line on the board. The person releases the block from rest so skillfully that the block slides down the inclined board without spinning. How fast is the block moving when the lowest edge of the block is aligned with the lower drawn line on the board?

SAC103

- 1) A person puts a wooden block of mass m on top of an ideal, massless, vertical spring of force constant k and unstretched/uncompressed length L_0 . The bottom of the spring is on a flat horizontal floor. The person holds onto the block by the sides of the block and presses downward on the spring with the block, compressing the spring until its length is L , then, suddenly, releases the block from rest. The block goes straight up into the air. At the highest point in its motion, how high above the floor is the block?
- 2) A block on a frictionless table is pushed against a horizontal spring of spring constant k , compressing it by an amount x . The block is released from rest. The spring decompresses. The block slides off the end of the table and lands on the floor a vertical distance y below. Assume the block has mass m . What is the speed of the block just before it hits the floor?
- 3) An experimental bus uses a massive, rapidly spinning flywheel, of moment of inertia I as a source of energy. As the bus uses energy, the flywheel slows down. Instead of refueling, the driver of the bus visits a spinning station, at which the flywheel is spun back up to high speed for further travel of the bus. Suppose the bus starts out, at rest, at the bottom of a mountain with the flywheel spinning at rate ω . Further suppose that the gross mass of the bus, including flywheel, driver, and occupants, is m . What is the maximum theoretical elevation increase that the bus can achieve without a visit to a spinning station? (Friction and air resistance are to be neglected in calculating the maximum theoretical value. The maximum theoretical value represents an upper limit which can never actually be achieved. In practice, the more one can reduce mechanical energy losses due to friction and air resistance, the higher the bus can go.)
- 4) In driving westward on a road, one goes over a hill. After the hill the road becomes level. A person releases a wheel of mass m and moment of inertia I , from rest, from a point near the top of the hill. At that point, the wheel is at an elevation h relative to the flat horizontal road to the west of that point. The wheel rolls westward, down the hill. In rolling, the wheel is both spinning and moving forward. If, upon arrival at the flat horizontal stretch of road, the wheel is moving forward at speed v' , how fast is it spinning?

SAC104

Unless otherwise specified in the problem the given symbols are to be considered known. Solve for the sought quantity in terms of the given symbols. Express your answer by writing the symbol for the sought quantity all by itself on the left side of an equation, and, on the right side of that same equation, writing an algebraic expression in which the symbols representing quantities are all given symbols.

- 1) An ideal massless horizontal spring of force constant (a.k.a. spring constant) k and unstretched length L_0 is perpendicular to a wall. One end of the spring is attached to the wall. The spring rests on a horizontal frictionless surface. A person brings a block of mass m into contact with the other end of the spring. The block is on the horizontal surface. The person pushes the block toward the wall until it, the block, is a distance d from the wall. The person releases the block from rest. Find the momentum that the block has after it loses contact with the spring.
- 2) Find the speed of a rock which has kinetic energy K and a momentum of magnitude p .
- 3) A bullet of mass m_1 is fired horizontally at speed v_1 into a block of wood of mass m_2 which is sliding at speed v_2 directly away from the gun on a frictionless horizontal surface. The bullet becomes stuck in the block of wood and the block of wood continues sliding away from the gun but at a different speed. Find that speed.
- 4) A tire swing hangs at rest over a gully. A girl wants to swing on it but can't reach it. The tire, of mass m_t , is oriented the same way it would be if the tire was rolling directly away from the girl. The girl throws a rock of mass m_r at the tire and hits the tire right in the middle of that part of the tire that is facing her. At the instant just prior to its collision with the tire, the rock is traveling horizontally, straight at the tire (defined to be the positive direction for the velocities in this problem), with velocity v_r . At the instant just after the collision the rock has a velocity v_r' . (Treat v_r' as a known quantity even though you are not even told whether the value of v_r' is positive or negative. A positive value of v_r' corresponds to the rock traveling in its original direction of motion after the collision, but, a negative value corresponds to the rock traveling back toward the girl after the collision. Your one correct answer will be valid for either case. It is up to the user of your answer to substitute the value of v_r' with the correct sign when using your answer for cases in which numbers, with units and direction information, are given.) Ignore the mass of the rope. Find the velocity of the tire immediately after the collision.
- 5) A block of mass m slides down a frictionless incline which makes an angle θ with the horizontal. Initially the block is a height h higher than it is when it is at the bottom of the incline. At the bottom, it strikes a block of mass M (M is greater than m) which is at rest on a horizontal surface. The collision is head-on and completely elastic.
 - a) Find the speed of each block immediately after the collision.
 - b) To what maximum new height will the lighter object slide up the incline after the collision?

SAC104

6) Block 1 of mass m_1 and block 2 of mass m_2 are both at rest on a flat horizontal frictionless table top that is a height h above the surface of the floor. The two blocks are attached to opposite ends of an ideal massless spring of unstretched length L_0 and force constant k . A person pulls the blocks apart. In doing so, she stretches the spring by an amount x . Then she simultaneously releases both blocks from rest. Measurements on the speeds of the blocks (relative to the table top) taken at time t (measured from the instant she releases the blocks), when the spring is still somewhat stretched, show that block 1 is moving toward block 2 with speed v_1' . How much is the spring stretched at that instant?

7) Two disks are sliding, without spinning, toward each other on a flat horizontal frictionless surface. The two disks have the same thickness. Disk 1 has diameter d_1 , mass m_1 and speed v_1 . Disk 2 has diameter d_2 , mass m_2 , and speed v_2 . The two disks collide. The collision is not completely elastic. After the collision, disk 2 is at rest and disk 1 is moving. How much of the kinetic energy of translation was transformed into other forms as a result of the collision?

Angular Momentum Accounting Problems

- 1) A man is standing on a horizontal stationary disk mounted on frictionless bearings such that it is free to rotate about a vertical imaginary axis that passes through the center of the disk. The moment of inertia of the disk is I . The man jumps up in the air with a twisting motion such that while he is in the air he is spinning with an angular momentum L counterclockwise (about the aforementioned vertical axis) as viewed from above. How fast and which way is the disk spinning while the man is in the air?

- 2) Rifles owe their accuracy in large part to the fact that they impart a spin to bullets. The bullets fired from a rifle acquire a spin about an axis parallel to, and through the center of, the rifle barrel. The principle of the conservation of angular momentum can be used to explain why this keeps the bullets from tumbling. (Tumbling results in air resistance forces which push the bullets off course in a random manner, something to be avoided if accuracy is desired.) To determine how fast a bullet fired from a rifle spins, a person fires a bullet of known moment of inertia I_B vertically downward into the center of a block of wood resting on a frictionless horizontal surface. The bullet becomes embedded in the block of wood and the block of wood is observed to be spinning with an angular velocity of ω' clockwise as viewed from above. The person then takes the block of wood with the bullet embedded in it and measures the moment of inertia with respect to the axis about which it had been rotating. She finds the moment of inertia of the combination object, block plus bullet, to be I_c . How fast and which way was the bullet spinning after it left the rifle but before it hit the block?

- 3) A horizontal disk of mass m and radius r is spinning at angular velocity ω counterclockwise, without friction, about an imaginary vertical axis through its center. (The moment of inertia of a uniform disk of mass m and radius r with respect to its axis of symmetry is $\frac{1}{2}mr^2$.) An identical disk that is not spinning is dropped from rest, from just barely above the spinning disk, onto the spinning disk. The two disks stick together and spin as one doubly-thick disk of radius r . Upon release, the upper disk is so close to the lower disk that the distance that it drops is negligibly small. How much mechanical energy is lost by the system (converted to another form or other forms) as a result of the upper disk being dropped upon, and sticking to, the lower disk.

- 4) Consider a horizontal uniform board of mass m_B , moment of inertia (with respect to a vertical axis through its center) I_B , length l , width w , and thickness t . Underneath the board is a horizontal disk of mass m_D , moment of inertia (with respect to a vertical axis through its center) I_D , radius R , and the same thickness as the board t . The center of the top of the disk is glued to the center of the bottom of the board and the board is attached, at its center, to the bottom of a thin vertical rod of negligible mass. The top of the rod is attached to the ceiling in such a manner that the rod is free to spin, with negligible friction, about the central vertical axis of the rod. The combination object is spinning freely, counterclockwise as viewed from above, about that vertical axis. The magnitude of the angular momentum of the combination object is L . The disk comes loose from the board and, while maintaining its horizontal orientation, falls to the floor. After the disk comes loose from the board, what is the angular velocity of the board?

SAC106

1) A car moves along a straight road with constant acceleration. At time 0, the car is 122 m ahead of the start line and moving forward at 80.0 km/h. 5.00 seconds later, the car is 398 m ahead of the start line.

- a) Find the acceleration of the car. After you calculate your answer, state your answer by giving a magnitude (a positive value with units) and a direction (write the word "forward" or the word "backward").
- b) Find the velocity of the car at time $t = 5.00$ s. State your answer by giving a magnitude and a direction.

2) A train travels along a straight track at a constant acceleration of 0.550 m/s^2 . At the start of observations, the train is already moving forward at 15 m/s and the nose of the engine is already 826 m past a railroad crossing sign that you, as an observer, are using as a reference position. How fast is the train going when the nose of the engine is 1.000 km past the same sign?

3) A cart on a straight, horizontal air track (to be considered frictionless) is caused to accelerate forward by means of a string tied to the front of the cart. The string extends forward horizontally from the cart and passes over a pulley. From there the string extends downward to a block tied to the end of the string. The block is falling straight downward and the string is pulling the cart forward such that both objects have an acceleration of magnitude 2.25 m/s^2 . At the start of observations, the cart is already moving forward at 1.02 m/s. How much time does it take, beginning at the start of observations, for the cart to achieve a speed of 2.26 m/s?

SAC106A

One-Dimensional Projectile Motion Problems

- 1) A boy throws a rock straight upward. The rock leaves the boy's hand at a point that is 1.40 m above ground level. The maximum altitude achieved by the rock is 10.3 m.
 - a) How fast is the rock going when it leaves the boy's hand?
 - b) How long does it take (starting at the instant when the rock leaves the boy's hand) for the rock to achieve its maximum altitude?
 - c) What is the total time of flight of the rock? (The time of flight is the duration of the time interval starting at the instant when the rock is released from the boy's hand and ending at the instant the rock hits the ground.)
 - d) How fast is the rock going when it hits the ground (at the instant the rock first makes contact with the ground but before the ground has caused any decrease in the speed of the rock)?
- 2) A girl drops a rock, from rest, from a point that is 14.0 m above ground level. 1.50 seconds later she throws a rock straight downward, releasing it from the same exact point at which the other rock was released, with a speed of 21.0 m/s. Do the rocks collide before either one hits the ground? If so, at what elevation above the ground does the collision occur? If not, how high above the ground is the thrown rock when the dropped rock hits the ground?
- 3) A person throws a rock straight downward. At the instant the rock is released, it is 21.4 m above the ground. 1.38 seconds later, the rock hits the ground. How fast was the rock going at the instant the person released it?
- 4) (Use numerical methods to solve this one.) An object is thrown straight downward with an initial speed of 7.77 m/s from a height of 35.0 m above ground level. On the way down, the object experiences a downward acceleration of $9.80 \frac{\text{m}}{\text{s}^2} - .0225 \text{ m}^{-1} v^2$ where the m and the s are the units meters and seconds respectively and the v is the speed of the object. The acceleration is reduced relative to the acceleration due to gravity because of air resistance. The object is "stirring" the air on its way down. What percentage of the object's initial mechanical energy is either transferred to the air or transformed into thermal energy of the object by the time the object hits the ground? (*Show all work. Include a printout of first page of the spreadsheet with graphs.*)
- 5) (Use numerical methods to solve this one.) There is a container of one kind of a liquid. A bead of mass 4.67 g is dropped from rest from a point just below the middle of the surface of the liquid. The bead falls downward toward the bottom of the container. Because of a buoyant force on the bead, the initial acceleration of the bead is only 4.20 m/s^2 . Furthermore, due to a viscous force on the bead, the acceleration decreases such that the total decrease in downward acceleration (from its initial acceleration) is proportional to the speed of the particle, until, when the acceleration becomes indistinguishable from zero, the particle is falling at a constant velocity called the terminal velocity of the particle. The constant of proportionality is 5.10 s^{-1} .
 - a) What is the value of the speed of the bead when it is falling at its terminal velocity?
 - b) How far has the bead fallen from its release point by the time its speed is 99% of the terminal speed of the bead?(*Show all work. Include a printout of the first page of the spreadsheet with graphs.*)

SAC107

"Collision" Type II Problems

1) A car traveling at 125 m/s is 85.0 m ahead of a second car that is moving at 105 m/s when the second car begins accelerating at 115 m/s^2 . The first car maintains a steady speed of 125 m/s and the second car maintains a steady acceleration of 115 m/s^2 . Starting at that instant when the second car begins acceleration:

- a) How long does it take for the second car to catch up with the first car?
- b) How far does the second car travel before catching up with the first car?

2) Two cars, car A and car B are moving toward each other on a straight road. Upon your initial observation the cars are 240 m apart. At that instant, from your point of view, car A is moving to the right at 28 m/s and car B is moving leftward at 12 m/s. The velocity of car A remains constant but car B has a steady acceleration of 15 m/s^2 .

- a) At what time, measured from the instant of your initial observation, do the cars pass each other?
- b) How far does car A travel before passing car B?
- c) How far does car B travel before passing car A?

3) A rock is launched straight upward at 15.0 m/s. 1.24 s later, a second rock is launched straight upward from the exact same position with a speed of 11.0 m/s. The release point (the point at which each rock leaves its launcher) is 105 m above the surface of the earth and the launch equipment is withdrawn immediately after the second launch allowing the rocks a free path to ground level. Ignore air resistance. If the rocks collide with each other before either rock hits the ground, answer the following two questions. Otherwise, write a statement to the effect that the rocks do not collide before the second rock hits the ground and justify your statement. In any case, for purposes of calculations, treat the rocks as point particles (do not concern yourself with the dimensions of the rocks).

- a) How many seconds after the release of the second rock does it take before the two rocks collide?
- b) How far from, and which way (above or below) from, the release point are the rocks when they collide.

4) Car A and car B are both traveling in the same direction on a straight horizontal road. Car B is moving forward at $(25.2 \pm .8) \text{ m/s}$ and continues to do so throughout the problem. Car A is moving forward at $(30.0 \pm 1.0) \text{ m/s}$ and is $(200.0 \pm 5.0) \text{ m}$ ahead of Car B when car A starts slowing down to a stop at a steady $(2.00 \pm .12) \text{ m/s}^2$. How far has car B traveled by the time car B passes car A? (For any problem in which you are provided data with uncertainty, include the estimated uncertainty in your answer.)

1-D Motion Graphs Homework Problems

In each case assume the motion occurs along a straight line path. Use the start line as $x = 0$ and use the forward direction (earliest direction of motion unless otherwise specified) as the positive x direction. Consider the initial conditions to pertain to $t = 0$. Sketch a graph of x vs. t , v vs. t , and a vs. t for each case.

1) (See the information in italics at the top of this page.) A car crosses a start line with a velocity of 30 m/s. The car continues at that velocity for 5 seconds. It then accelerates smoothly obtaining a velocity of 65 m/s after 5 seconds. Then the driver applies the brakes and the car slows uniformly to rest in 5 seconds.

2) (See the information in italics at the top of this page.) A car which is at rest at a position 25 meters ahead of the start line begins, at $t = 0$, to accelerate uniformly in the forward direction, obtaining a speed of 25 m/s at the end of 10 seconds. It continues at that speed for 20 seconds at which point the driver applies the brakes and the car slows smoothly to rest at the end of 5 seconds. Then the car accelerates uniformly in the backward direction obtaining a speed of 10 m/s in reverse after 5 seconds. The driver immediately applies the brakes and the car smoothly slows and comes to a stop after 5 seconds.

3) (See the information in italics at the top of this page.) At the start of observations, a car is backing up across the start line at a constant velocity of 15 mph. The car continues to move backwards at that speed for 5 seconds. Then the driver applies the brakes and the car slows smoothly to rest in 5 seconds. As soon as the car stops, it begins accelerating smoothly in the forward direction achieving a speed of 75 mph after another 15 seconds. The car travels at that speed for 10 seconds. Then the car slows smoothly to a speed of 55 mph in 5 seconds. It continues at 55 mph for 10 seconds at which point observations on the motion of the car cease.

4) (See the information in italics at the top of this page.) A car at rest at the start line immediately begins to accelerate forward smoothly, obtaining a speed of 55 mph at the end of 10 seconds. Then the car immediately begins to slow down uniformly, obtaining a speed of 35 mph after 5 seconds. The car continues at that speed for 10 seconds at which point it begins to decelerate uniformly, coming to rest after another 5 seconds.

SAC109

Vector Addition Homework

In each of the cases below, vector directions are specified by means of the mathematics convention. The spreadsheet "add2vectors.xls" is available at the Calculus-Based Physics web site.

1) Add the following two displacement vectors analytically. Use the spreadsheet "add2vectors.xls" to add the same two vectors. Make sure you get the same result with each method.

4.45 m at 165°

8.82 m at 44.0°

2) Add the following two velocity vectors analytically. Use the spreadsheet "add2vectors.xls" to add the same two vectors. Make sure you get the same result with each method.

19 m/s at 0°

37 m/s at -78°

3) Add the following two acceleration vectors analytically. Use the spreadsheet "add2vectors.xls" to add the same two vectors. Make sure you get the same result with each method.

9.80 m/s^2 at -90.0°

8.82 m/s^2 at 66.0°

SAC109A

Constant Acceleration in 2 Dimensions

1) A particle moves on a horizontal surface upon which a Cartesian coordinate system has been laid out. At time 0 the particle is at the origin and moving with a velocity of 4.30 m/s in the +x direction. The particle has a constant acceleration of 2.00 m/s² in the +y direction.

a) Find the position of the particle at time $t = 2.5$ s.

b) Find the magnitude and direction of the velocity of the particle at time $t = 2.5$ s.

2) Particle A and particle B move on one and the same horizontal surface. At time 0, particle A is at rest, 6.00 meters west of particle B. Particle B is traveling northward at a constant 12.0 m/s. Starting at time 0, particle A accelerates steadily, along a straight line, at 22.0 m/s². In what compass direction must particle A travel in order for it to hit particle B? (Hint: The well-known trigonometric identity $(\sin \theta)^2 + (\cos \theta)^2 = 1$, true for any angle θ , is useful in the solution of this problem.)

3) A car with a northward heading is at rest on a straight narrow (exactly as wide as the car) horizontal one-lane road that extends south to north. The front end of the car is 12.0 m south of the center a straight railroad track that extends east to west. The nose of a train that is headed toward the road at a constant speed of 18.0 m/s is 61.0 m from the road at the instant the car begins a steady northward acceleration. The car is 3.60 m long and the train is 2.40 m wide. What is the minimum value of acceleration that the car must have in order to cross the track before the train gets there, without being hit by the train.

4) Consider two particles on an x-y coordinate system. At time zero, particle 1 is at the origin with a velocity v_1 in the +x direction. The velocity of particle 1 is constant. Particle 2 is at $(x_{02}, 0)$ (where x_{02} is known to be less than 0) at time 0 with an initial velocity of unknown magnitude at a known angle θ between 0° and 90°. Particle 2 has a constant acceleration of a_2 in the -y direction (the value of a_2 itself is known to be positive). Find the magnitude that the initial velocity of particle 2 must have in order for particle 2 to hit particle 1.

5) A particle having charge (-49.2 ± 7.5) C and mass $(2.07 \pm .25)$ grams is dropped from rest in an evacuated chamber from a height of $(.210 \pm .015)$ m above the flat horizontal floor of the chamber. A uniform horizontal electric field within the chamber causes the particle to experience an eastward acceleration of $(1.20 \pm .025)$ m/s² in addition to the acceleration due to gravity $(9.8010 \pm .0050)$ m/s² at the location of the chamber. Where, relative to the point, on the floor of the chamber, directly below the release point, does the particle hit the floor of the chamber?

Projectile Motion Problem

Ignore air resistance in all of these problems.

- 1) A rock is thrown from a cliff. The rock leaves the thrower's hand with a velocity of 24 m/s at an angle of 68° below the horizontal. The rock leaves the thrower's hand at a height of 98 m above the flat horizontal land below. How far downrange from the release point does the rock go before it hits the ground? (The downrange distance is the horizontal distance—the distance measured along the ground from the point at ground level that is directly below the release point, to the point at which the rock hits the ground.)
- 2) A person hits a golf ball over flat level ground directly toward a wall which is facing the golfer. The ball does hit the wall. The ball leaves the golf club at ground level from a point that is 52.0 m from the wall with a velocity of 33.0 m/s at an angle of 29.0° above the horizontal. How high up on the wall does the ball hit?
- 3) A person throws a rock directly forward over flat level ground. The rock leaves the thrower's hand at a height of 1.67 m above ground level with a velocity of 14.2 m/s directed along the horizontal. How far forward does the rock go before it hits the ground?
- 4) A rock of mass 1.10 kg and volume 283 cm^3 is irregular shape. A person throws the rock with a launch angle of 39.0° (above the horizontal) over flat level ground from a height of 0.668 m above the ground. Ground level is at an elevation of 138 m above sea level. The rock goes 7.40 m down range before it hits the ground. The rock bounces off the ground achieving a maximum height of 12.0 cm and traveling an additional 18.0 cm down range before coming to rest with a thud. Find the momentum of the rock at the instant it leaves the thrower's hand.

SAC111

1) The muzzle velocity of a BB gun is 57.0 m/s. (The muzzle velocity of a gun is the speed, relative to the gun, with which the projectile fired by the gun, leaves the muzzle of the gun.) A girl levels the gun and points the gun due east while she is in a car that is heading due north at 26.1 m/s. Then she pulls the trigger, thus firing a BB. How fast, and which way, relative to the road, is the BB going as it leaves the muzzle of the gun. Neglect recoil of the gun.

2) A boat is due east of an island. The driver of the boat wants to get to the island as soon as possible. At full throttle, with the rudder aligned with the keel, in still water, the boat moves at a speed of 4.6 m/s in the direction in which it is pointing. The water in which the boat finds itself is flowing northward at 2.5 m/s. With the engine at full throttle and the rudder aligned with the keel, in which compass direction should the boat be pointing so that its velocity is directed straight at the island?

3) A person is driving a forklift on the main deck of an aircraft carrier. The driver is following a line, painted on the flat horizontal deck of the aircraft carrier, that makes an angle of 75.0° , measured clockwise from the forward direction as viewed from above, with the centerline of the ship. (The forklift is thus moving closer to the bow of the ship, and, at the same time, closer to the starboard side of the ship.) The speedometer on the forklift reads 3.60 m/s. The ship itself is moving through still water at 2.90 m/s at a compass heading of 355° . How fast and in what direction is the forklift moving relative to the water?

4) In a so-called “paper river” laboratory exercise a student is provided with a motor-driven loop of paper and a flat horizontal table that stands on top of a lab bench. The paper is 0.100 mm thick and 21.59 cm wide. The table top is square, measuring 50.0 cm along an edge. The paper is caused to loop over and under the table such that there is always a single thickness of paper sliding rightward (which we define to be the $+x$ direction) at 0.0856 m/s on the table top as viewed from where a student typically sits or stands when working at the lab bench. The student is provided with a small battery-operated toy car that has a fixed velocity of 0.110 m/s along the straight line direction in which it is pointing, relative to whatever flat horizontal surface she puts it on when it is turned on. The line, *on the table*, along which the edge of the paper nearer the student is moving is defined to be the x axis, and a line *on the table*, near the left edge of the table from the student’s point of view, extending away from the student perpendicular to the x axis, is the y axis with the away-from-the-student direction being the $+y$ direction. With the paper moving, the student turns on the toy car and gently drops it on the paper as close as possible (neglect the size of the car in your calculations) to the point where the two axes cross, the origin of the already-described coordinate system, such that the direction in which the car is pointing is 25.0° clockwise (as viewed from above) from the $+y$ direction. The car comes off the paper (onto the table) at the edge of the paper farther from the student. Where (give the coordinates on the table using the specified coordinate system) on the table top does the car come off the paper?

Free Body Diagrams

Draw the free body diagram for each of the objects identified in parentheses at the end of each of the characterizations below:

1) A child pulls a sled across a frozen pond using rope making an angle θ with the horizontal. Do not neglect friction. (the sled)

2) A car is parked (rests) facing uphill on an incline. (the car)

3) A rope is attached to a block of mass m . The other end of the rope is passed over a pulley and pulled upon so that the block is lifted straight upward at constant acceleration a . (the block)

4) A horse pulls a sleigh horizontally. (the horse)

SAC 112A

1) Considering F_{kf} , θ , g , and the mass m of the block, in the free body diagram at right to be known, and given that the acceleration of the object is directed along the positive x axis, find a and F_N .

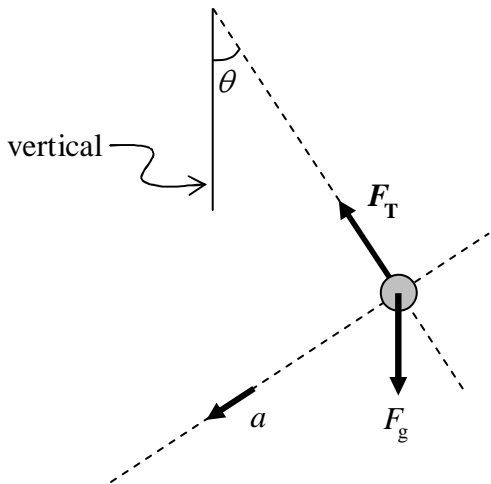
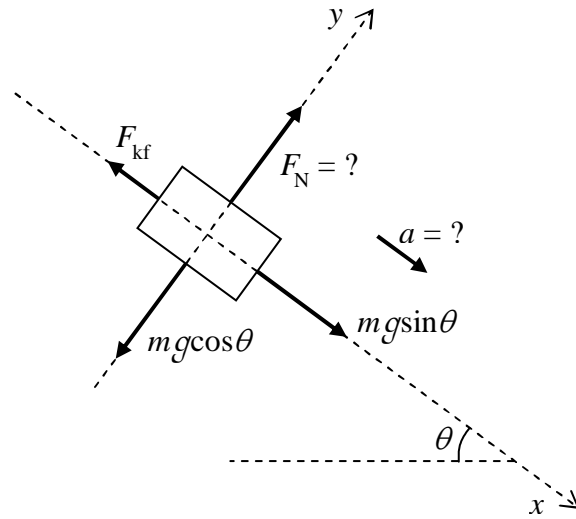

2) In the diagram at left, the two dashed lines are at right angles to each other. Assuming that the gravitational force F_g on the ball depicted in the diagram is 5.00 N, and the angle θ is 32.8° , find F_T and a .

3) In the free body diagram at right, the mass m of the ball is 0.200 kg and the value of g is $9.80 \frac{\text{N}}{\text{kg}}$. Find F_B .

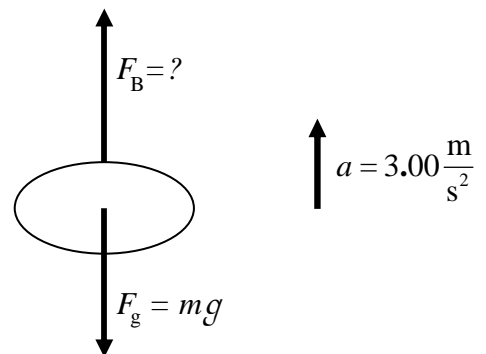

SAC 112A

4) The block depicted at right is moving rightward (in the same direction the depicted acceleration arrow is pointing) on a frictionless horizontal surface with a speed (at the instant depicted) of 17.5 m/s. Find magnitude F_N of the normal force exerted on the block by the frictionless horizontal surface.

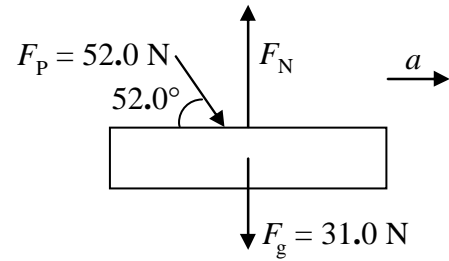

SAC113

- 1) For each of the following cases, neglect air resistance. If there is a rope, neglect the mass of the rope. If there is a pulley, assume the pulley to be frictionless and massless.
- There is an eye hook in a top corner of a crate and another eye hook in the opposite top corner of the crate. One end of a piece of rope is tied to one of the eye hooks. The rope extends vertically upward, passes over a pulley and from there extends vertically downward to the other eye hook to which the other end of the rope is tied. The crate is hanging at rest. Draw the free body diagram of the crate.
 - A boy is pushing a crate across a flat horizontal concrete floor at constant velocity. The floor is not frictionless. The boy is pushing both downward and forward on the crate at the same time. In fact, he is exerting a force on the crate which is directed at an angle of 25° below the horizontal. Draw the free body diagram of the crate.
 - A woman in the loft of a barn is hoisting a crate upward by means of a rope which is tied to the ridgepole of the roof of the barn. The rope extends straight downward to a pulley fastened to the top of the crate. The rope passes under the pulley and from there extends straight upward to the hands of the woman. She is pulling upward on that part of the rope. At the instant in question, the rate at which the woman is raising the crate is increasing. Draw the free body diagram of the crate-plus-pulley.
 - A person is pulling a crate across a flat level asphalt driveway by means of a rope tied to the crate. The rope extends upward and forward from the crate such that it makes an angle of 19.0° with the horizontal. At the instant in question, the crate is speeding up. The driveway is not frictionless. Draw the free body diagram of the crate.
- 2) A block rests on a ramp. The ramp is not frictionless. The ramp is flat, but tilted, so that it makes an angle of 21.0° with the horizontal. The upper end of the ramp abuts a wall to which that end of the ramp is attached. The lower end of the ramp rests on a horizontal floor. Attached to the wall, at the top of the ramp is one end of a spring. The spring extends down the ramp, parallel to the surface of the ramp, and, the other end of the spring is attached to the block. A woman pulls the block down the ramp and releases it from rest. The block is sliding up the ramp. At the instant in question, the block has slid so far up the ramp that the spring is compressed, but, the block is still sliding up the ramp. Draw the free body diagram of the block.
- 3) One end of a spring is fixed to a wall at a point that is 1.50 m below the ceiling. A string segment of length 1.60 m extends from a point on the ceiling to the other end of the spring, a point on the spring which we shall call point A. One end of another string segment, a short string segment, is also attached to point A. The other end of the short string segment is attached to the handle of a coffee mug. The coffee mug is thus suspended from point A by the short length of string. The point on the ceiling to which the 1.60 m string segment is attached has been chosen to make the spring extend horizontally, perpendicular to the wall. Draw the free body diagram of point A. Assume that the spring extends southward, away from the wall, and depict the configuration as it would appear if it were viewed from a position east of point A.

SAC113

4) A 25 year old man of mass 85.0 kg is pushing a 3 year old child of mass 31.0 kg on a swing. The swing seat is a molded-plastic boxlike seat of the sort sometimes found on swings for very small children. The mass of the seat is 0.800 kg and the child is holding on to the front of the seat rather than the pair of low mass chains from which the seat is suspended. At the instant in question, the child has swung back to the maximum backward position and has swung forward a small fraction of the distance that she has to swing in order to reach the lowest position of her motion, the chains make an angle of 28.0° with the vertical, and the man is pushing with force of magnitude F_M on the back of the swing seat in a direction perpendicular to the plane of the chains. The center of mass of the child plus seat is 2.70 m from the point on the swing set midway between the two points at which the chains are attached to the frame of the swing set. The chains are straight. At the instant in question, the child has a speed of 0.680 m/s. Draw the free body diagram of the system consisting of the child plus the seat.

SAC114

1) A man attempts to pull a box up a ramp by means of a rope tied to the box. The rope is parallel to the ramp as the man pulls on it in a direction straight up the ramp. The maximum force that the man is able to exert on the rope is 425 N. The box is initially at rest. The earth's gravitational force on the box is 495 N. The ramp makes an angle of 30.0° with the horizontal. The coefficient of static friction between it and the ramp is 0.60 (with no units). Is the man able to budge the box?

2) A cart on a horizontal air track with no air supply slides through a photogate with a speed of 2.1 m/s. It comes to rest at a point 0.64 m from the photogate. Find the coefficient of kinetic friction between the cart and the track.

3) An Atwood machine consists of a string which passes over a pulley and has an object attached to either end, as depicted at right. The axis of the pulley is fixed so the pulley can only rotate about its axis. Referring to the diagram, consider m_2 to be greater than m_1 . Upon release, the block of mass m_2 accelerates downward and the block of mass m_1 accelerates upward at one and the same rate. Assume the pulley to be massless and frictionless. Find the magnitude of the acceleration of both blocks.

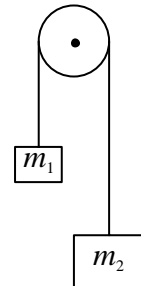

4) Find the acceleration of a block on a flat frictionless surface at angle θ to the horizontal.

5) Find the frictional force on a block of mass m at rest on a flat surface at angle θ to the horizontal.

6) Find the coefficient of static friction for the friction between a block and a flat surface if θ_{MAX} is the biggest angle of the surface to the horizontal possible such that the block does not slip.

7) Find the acceleration of a block sliding down a flat surface where the flat surface makes an angle θ with the horizontal and the coefficient of friction between the block and the surface is μ_k .

8) A block of mass m_1 is held in place on a flat, horizontal, frictionless surface by a person. A string extends horizontally from that block to a frictionless, massless pulley at the edge of the frictionless surface, over the pulley, and downward to a second block of mass m_2 which hangs at rest, suspended by the string. Find the acceleration of the blocks after the person lets go.

9) A box is dragged across a horizontal floor at constant velocity by means of a rope tied to the front of the box. The rope makes an angle of 12° with the horizontal (above the horizontal). The magnitude of the force applied to the rope is half the magnitude of the earth's gravitational force on the box. Find the coefficient of friction governing the friction between the box and the floor. Write your answer to two significant figures.

SAC114

10) A block of mass 7.60 kg is on a flat horizontal table top. One end of a piece of string is attached to what, from your point of view, is the top right edge of the block. The string extends upward and rightward, at an angle of 16.0° to the horizontal, away from the block and over a frictionless pulley. A ball of mass 3.20 kg hangs at rest from the other end of the piece of string. The block is at rest. Neglect the mass of the string.

- a) Find the frictional force exerted on the block by the table top.
- b) Would the block actually remain at rest, as specified in the statement of the problem, if the coefficient of static friction for the interaction between the block and the table top was 0.450 ?

11) The top end of a vertical spring of spring constant 5.20 N/m and length 78.0 cm is fixed to the ceiling. The bottom end is attached to the top of a block of mass 1.66 kg which is at rest (at what we will refer to as its original position) on a flat frictionless horizontal surface. The spring is neither stretched nor compressed. A person slides the block over to one side and releases it from rest. The block slides back toward its original position.

- a) What is the acceleration of the block when, subsequent to its release, the block is 45.0 cm from its original position?
- b) At the instant in question in part a, what is the normal force on the block?

12) A block of mass 2.06 kg on a frictionless horizontal surface is attached to a wall by means of an ideal horizontal spring of negligible mass and a force constant of 128 N/m . At the start of observations the block has a momentum of $7.77\text{ kg}\cdot\text{m/s}$ directed along the line along which the spring extends, straight toward the wall, and the spring is neither stretched nor compressed. Find the acceleration of the block when the spring is at maximum compression.

Universal Law of Gravitation Problems

1) An object is released from rest at height R_E (equal to the radius of the earth) above the surface of the earth. Find the speed of the object at the surface of the earth, given that:

- The mass of the earth is $m_E = 5.98 \times 10^{24}$ kg .
- The radius of the earth $R_E = 6.38 \times 10^6$ m .

2) Find the escape velocity for an object at the surface of the moon, given that:

- The mass of the moon is $m_m = 7.35 \times 10^{22}$ kg .
- The radius of the moon is $r_m = 1.74 \times 10^6$ m .

3) Consider an object on the line passing through the center of the earth and the center of the moon. Treating the earth and the moon as point particles, how far from the center of the earth would that object have to be in order for the net gravitational force exerted upon it by the earth and the moon to be zero?

Now consider the actual moon and the actual earth (no longer treating them as point particles): Would the point that you found above be inside either the earth or the moon? (Justify your answer, and, if your answer is yes, state which body the point would be inside of.)

- The mass of the earth is $m_E = 5.98 \times 10^{24}$ kg .
- The mass of the moon is $m_m = 7.35 \times 10^{22}$ kg .
- The distance from the center of the earth to the center of the moon is 3.84×10^8 m .
- The radius of the earth $r_E = 6.38 \times 10^6$ m .
- The radius of the moon is $r_m = 1.74 \times 10^6$ m .

4) With how much momentum would a golf ball of diameter 4.27 cm and mass 45.9 g have to be launched from the surface of the moon in order to achieve a maximum distance of 942 km from the surface of the moon.

SAC116

1) A puck of mass 425 g is fastened to a vertical rod by a piece of string. There is a loop in the end of the string that fits on the axel such that the loop can spin frictionlessly on the rod. The rod is rigidly attached to a frictionless horizontal surface. The puck is moving on the horizontal surface in a circle of radius 85.0 cm centered on the axis of symmetry of the rod. The string is taut and horizontal. The speed of the puck is 2.20 m/s. Find the tension in the string.

2) A ball of mass 185 g is suspended from the ceiling by a string of length 1.20 m. A person sets the ball in motion such that, after the person is no longer touching the apparatus, the ball is moving in a horizontal circle of radius 0.380 m. Find the speed of the ball.

3) A block of mass 554 g is fastened to a tiny massless ring on a rigid vertical frictionless axel of negligible diameter by a massless horizontal spring characterized by a force constant of 39.5 N/m. The axis is rigidly attached to a frictionless horizontal surface. When the block is at rest on the frictionless surface, with the spring unstretched, the center of the block is 0.540 m from the axel. A person sets the block in motion, such that, after the person releases the apparatus, the block is moving in a circle, centered on the axel, at a steady speed of 3.60 m/s. Find the radius of the circle.

4) How fast would an object have to be moving in order to be in a circular orbit about the moon at an altitude of only 101 m above the surface of the moon?

- The mass of the moon is $m_m = 7.35 \times 10^{22}$ kg .
- The radius of the moon is $r_m = 1.74 \times 10^6$ m .

5) Find the mass of the earth based on the following properties of the moon's orbit about the earth:

- The moon's orbit is approximately a circle of radius 3.84×10^8 m.
- The moon takes 27.3 days to go around the earth.

6) We are viewing the device depicted at right from above. It consists of a solid cylinder of length $(2.50 \pm .10)$ cm and mass $m = (118.0 \pm 2.0)$ g in a frictionless tube. The cylinder is connected to one end of the tube by means of a spring. When the device is horizontal and at rest, the spring is relaxed (neither stretched nor compressed) and the front face of the cylinder (the right edge in the diagram) is $(6.00 \pm .20)$ cm from the button at B. The device is mounted on the vertical shaft of a gear turned by an engine so that when the engine is running the device is rotating about a vertical axis (perpendicular to the page in the diagram) through A. The device is designed to protect the engine from spinning too fast. Whenever the front face of the cylinder hits the button at B, it is $(13.4 \pm .20)$ cm from point A and it shuts down the engine. What spring constant is required if the gear shaft is not supposed to spin faster than (960 ± 18) rpm? (Neglect the mass of the spring.)

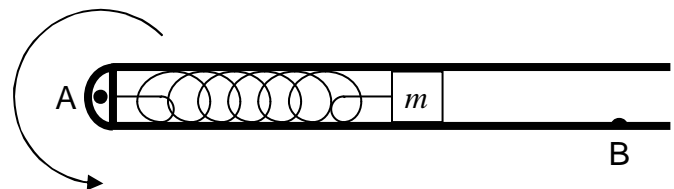

Rotational Motion Problems

- 1) Starting with the Merry-Go-Round at rest, a person pushes on a Merry-Go-Round in such a manner as to cause that Merry-Go-Round to experience a steady angular acceleration of 0.405 rad/s^2 .
 - a) How fast is the Merry-Go-Round spinning after 5.00 seconds?
 - b) How many rotations does the Merry-Go-Round complete during the first 5.00 s of its motion?

- 2) A girl turns her bicycle upside down and spins the front wheel. Spin rate measurements taken on the wheel while it is spinning freely show that the wheel slows steadily from 85.2 revolutions per minute to rest in 46.5 seconds.
 - a) Find the angular acceleration of the wheel.
 - b) Starting at the instant when the angular speed of the wheel is 85.2 revolutions per minute, how many revolutions does the wheel complete by the time it comes to rest?

- 3) To start a lawn mower, a person, by means of a pull-cord, must cause the crankshaft of the lawnmower motor, starting at rest, to achieve an angular speed of at least 94.0 rad/s in 22.2 revolutions. Assuming the person pulls the cord in such a manner that the crankshaft experiences a constant angular acceleration, what is the minimum required value of that angular acceleration?

- 4) A horizontal wheel of radius 0.320 m is spinning clockwise at 225 rpm (where "rpm" stands for "revolutions per minute") as viewed from above. Its spin rate is increasing at the rate of 337 rad/s^2 .
 - a) Find the velocity (magnitude and direction) of that point on the rim that, at the instant in question, is due west of the center of the wheel.
 - b) Find the acceleration (magnitude and direction) of that point on the rim that, at the instant in question, is due west of the center of the wheel.

- 5) A drill is spinning at +995 rpm when it is turned off. When it is turned off, but still spinning, the drill chuck experiences an angular acceleration of -0.525 rad/s^2 . Starting from the conditions at the instant the drill is turned off:
 - a) How long does it take for the drill chuck to stop spinning?
 - b) Through how many revolutions does the drill chuck turn before coming to rest?

- 6) (Use numerical methods for this one.) The blade array of a fan is spinning at 2500 rpm when the fan is shut down. Starting from the instant the power is shut down, the blade array of the fan experiences an angular acceleration of $-12.0 \frac{\text{rad}}{\text{s}^2} - .0065 \text{ rad}^{-1} \omega^2$ until it comes to rest. How long does it take for the blade array to come to rest? (*Show all work. Include a printout of the first page of the spreadsheet with graphs.*)

SAC118

Rolling and Torque Problems

1) A person opens a door of width W by means of a horizontal force F applied to the edge of the door farthest from the hinge in a direction perpendicular to the doorway (to the right in the diagram). Find the torque exerted on the door about the hinge by the person when the door is open an angle θ .

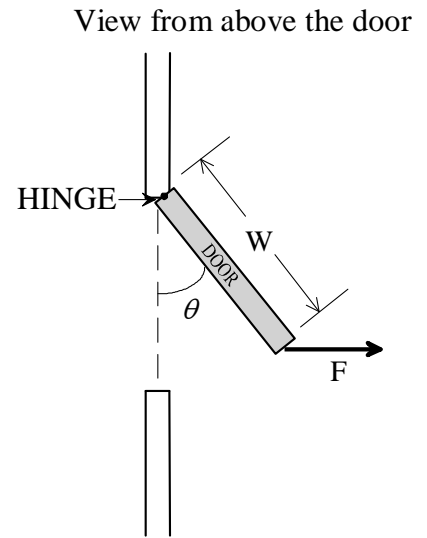

2) A uniform rod of length L and mass m , free to pivot about a pin at point P (see the diagram at right) is supported in a horizontal position by a cable attached to the end of the rod farthest from the pin. The other end of the cable is fastened to a point a distance h directly above the pin. The tension in the cable is T . Find the torque, about the pin axis, exerted on the rod by the cable.

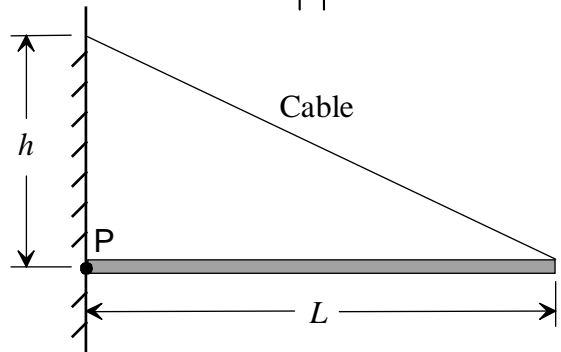

3) The wheels on a car are 50.0 cm in diameter. How many revolutions per minute are the wheels making when the car is going 65.0 mph?

4) A uniform disk of radius r is rolling without slipping down a flat surface at an angle θ to the horizontal. The moment of inertia of the disk can be expressed in terms of the mass m of the disk as $\frac{1}{2}mr^2$. Find the acceleration of the center of mass of the disk.

SAC119

1) An Atwood machine consists of a string which passes over a pulley and has a block attached to either end, as depicted at right. The axis of the pulley is fixed so the pulley can only rotate (frictionlessly) about its axis. m_2 is greater than m_1 . Upon release, the block of mass m_2 accelerates downward and the block of mass m_1 accelerates upward at one and the same rate.

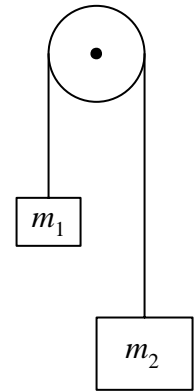

Assume the pulley to be a uniform disk of mass m and radius r . (The moment of inertia of a uniform disk with respect to its axis of symmetry is $\frac{1}{2}mr^2$.) Assume that the pulley is frictionless with respect to rotation about its axis. Assume that the string does not slip. Find the acceleration of each block and the angular acceleration of the pulley.

2) A child pushes on one point, call it point P, on the rim of a merry-go-round with a force of constant magnitude F whose direction is always at an acute angle θ counterclockwise (as viewed from above) from the outward radial direction at point P. (The outward radial direction at point P is the direction in which one would be pointing if one was at the center of the merry-go-round and pointing at point P.) The merry-go-round is initially at rest, has radius r , has moment of inertia I , and spins on a frictionless shaft. How much time does it take for the merry-go-round to achieve an angular velocity of magnitude ω ?

3) A uniform trap door in a horizontal floor has mass m and length L (where the length is measured from the hinge to the opposite edge of the door). The trap door swings open under the influence of the earth's gravitational force. The moment of inertia of the door with respect to its hinge is I . Find the angular acceleration of the door when it makes an angle θ with the horizontal.

4) (Use numerical methods for this one.) The blade array of a fan has a moment of inertia of $.0450 \text{ kg}\cdot\text{m}^2$ and is spinning at 2500 rpm when the fan is shut down. The bearings on which the array spins exert a constant retarding torque of $.540 \text{ N}\cdot\text{m}$ as long as the blade array is spinning but no torque when it is not, and, the air exerts a retarding torque having a magnitude given by $(2.925 \times 10^{-4} \text{ N}\cdot\text{m}\cdot\text{s}^2)\omega^2$.

- How long does it take for the blade array to come to rest?
- What percentage of the kinetic energy of rotation that the blade array had at the instant the fan was shut down does it have after half the time found in part a has elapsed since shutdown?

(Show all work. Include a printout of the first page of the spreadsheet with graphs.)

SAC120

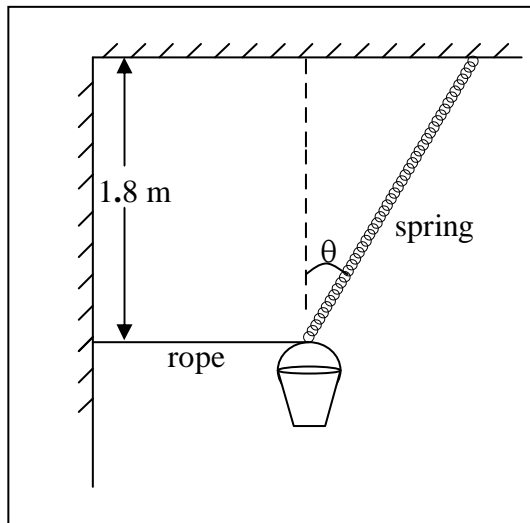

- 1) A bucket is supported by a horizontal rope and a spring as shown at left. The mass of the bucket is 4.8 kg and the force constant for the spring is 96 N/m. The unstretched length of the spring is 1.8 m.
 - a) Find the angle θ that the spring makes with the vertical direction.
 - b) Find the tension in the rope.

2) Refer to the diagram at right which gives a side view of the Beck Centripetal Force Apparatus. When unstretched, the spring is 10.0 cm shorter than it is when it is stretched to the extent depicted in the diagram. In carrying out part of a rotational motion laboratory exercise using the Beck Centripetal Force Unit, suppose that it is found that the object whose circular motion is to be investigated (object 1 in the diagram) has a mass of 510 g and is at a distance of 18 cm from the axis of rotation when it is hanging straight down at rest and that it takes an object of mass 460 g (hanging from the end of the string that passes over a pulley and is attached to object 1) to stretch the spring enough so that object 1 hangs straight down at rest with the spring attached as depicted in the diagram. What is the force constant of the spring?

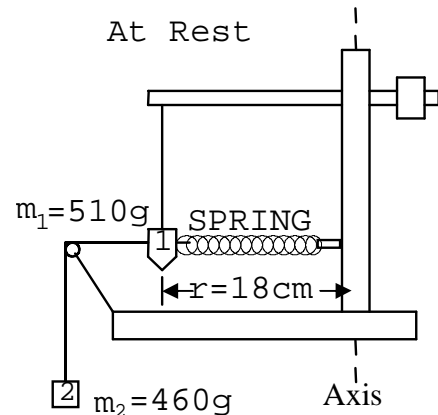

- 3) A block of mass 1.40 kg lies on a flat frictionless ramp that extends downward and away from a wall. The ramp makes an angle of 23.0° with the horizontal. The block is held in place by a string, one end of which is fastened to the wall, the other end of which is attached to the block. The string makes an angle of 35.0° with the horizontal. Find the tension in the string.
- 4) A block is on a flat wooden board. The board is tilted at that angle which causes the block to be on the verge of slipping. The angle is measured to be 13.1° . Find the coefficient of static friction for the block/board interface.
- 5) One end of a string segment of length 32 cm is attached to a frictionless wall. The other end is attached to the surface of a ball of mass 0.24 kg and radius 7.2 cm. The ball is thus suspended from a point on the wall by the string such that the ball is in contact with the wall. The imaginary line on which the string lies passes through the center of the ball. Find the tension in the string and the normal force exerted on the ball by the wall.

SAC121

Statics Problems

1) A horizontal board of mass 45 kg and length 2.8 m rests on two vertical supports as shown at right. If the board exerts a force of 190 N on the support at the left end of the board, find the position of the other support. Assume the earth's gravitational force on the board to act on the center of the board.

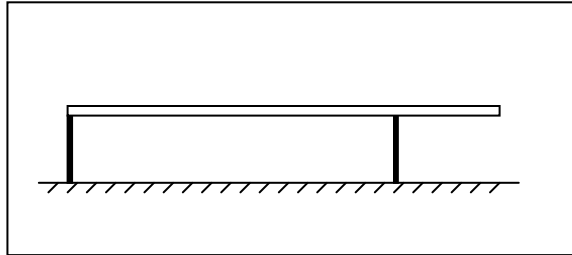

2) A rod of mass 14 kg is supported so that it extends horizontally from a vertical wall as shown at right. It is pinned at A such that, if the rope were cut, the rod would rotate clockwise about point A. Find the tension in the rope and the force exerted on the rod by the pin at A. Assume the earth's gravitational force on the rod to act on the center of the rod.

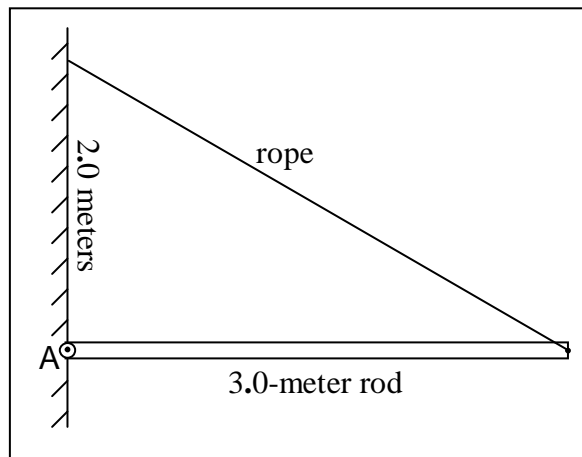

3) The 2.0 m bar depicted at right is pin connected at its left end and supported by a vertical rope at its right end. The pin connection at point P in the diagram is such that if the rope were cut, the bar would swing downward, rotating clockwise about the pin. The rope is not cut. The bar has a mass of 26 kg and the earth's gravitational force on the bar can be considered to be acting at its center. The bar makes a 24° angle with the horizontal. Find the tension in the rope and the force exerted on the bar by the pin.

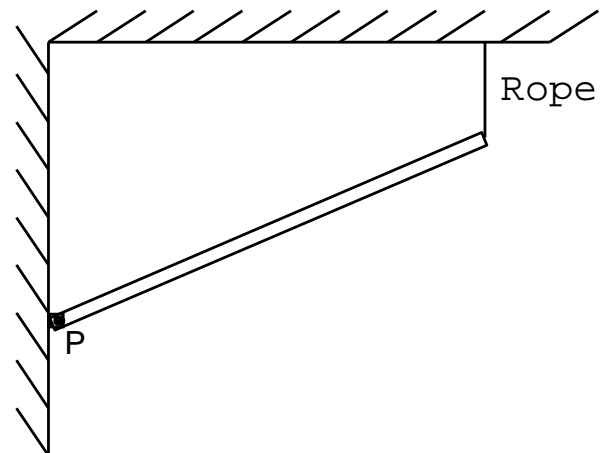

4) A rod extends 1.1 m horizontally from a fixed clamp. The rod is longer than 1.1 m but part of the rod is in the jaws of the clamp. The mass of the 1.1 m length of the rod sticking out of the clamp is 0.30 kg. Find the force and the torque exerted on the 1.1 m rod segment in question by that segment, of the same rod, that is in the jaws of the clamp.

SAC121

5) A 0.150 m rod of mass 0.390 kg is fixed attached to a wall so that it extends outward away from the wall perpendicular to the wall. The rod has a diameter of 0.030 m. One face of a meter stick of mass .128 kg is in contact with the rod at the 80 cm mark on the meter stick. The stick is perpendicular to the rod. The end of the meter stick marked 0 cm is on the floor. There is a thin layer of oil on the floor making it so slippery that any frictional force exerted by the floor on the end of the stick is negligible. The meter stick makes an angle of 33.2° with the floor. Find the frictional force exerted on the meter stick by the rod.

SAC122

Work-Energy Problems

1) In throwing a ball of mass 0.28 kg a thrower moves the ball with his hand on a curved path of total path length 1.0 m from rest at a height of 1.5 m above ground level to a final speed of 45 m/s at the end of the curve where he releases the ball at a height of 1.5 m above ground level.

Neglect any spin that the pitcher might impart to the ball.

- a) Find the work done on the ball by the thrower.
- b) Find the average magnitude of the force exerted on the ball by the thrower during the throw.

2) In the course of mowing a lawn a person pushes a lawn mower forward 15 m at constant velocity along a straight horizontal path by applying a force of 590 N directed along the handle of the lawn mower. The lawn mower handle makes an angle of 41° with the horizontal direction.

- a) How much work is done on the lawn mower in this process?
- b) How much work is done by the person on the lawn mower during this process?

3) A Styrofoam ball of mass 20.0 kg is dropped from rest. After falling straight downward a distance of 18.0 meters, the ball has a velocity of 15.9 m/s.

- a) Find the work done on the ball by the air on the way down.
- b) Find the average force of air resistance that acts on the ball on the way down.

SAC123

1) A bucket of water is raised from a well by means of a hand crank. The bucket-plus-contents has a total mass of 12.0 kg. The hand crank has a moment of inertia of $0.850 \text{ kg}\cdot\text{m}^2$. When the bucket is 11.0 m above the water level, the hand crank is released from rest. As the bucket falls, the rope connecting the bucket to the hand crank unwinds from the hand crank and the hand crank spins faster and faster. At the last instant before the bucket hits the water, the bucket is falling at a rate of 1.10 m/s. How fast is the hand crank spinning? (Neglect air resistance and neglect frictional torque on the shaft of the crank.)

2) A person applies a tangential force of 255 N to the rim of an empty, frictionless, initially-at-rest merry-go-round of radius 1.60 m and moment of inertia $329 \text{ kg}\cdot\text{m}^2$ for exactly one revolution. The person releases the merry-go-round at the end of that one revolution.

- Calculate the work done by the person as the force-along-the-path times the length-of-the-path.
- Calculate the work done by the person as the torque times the angle-of-rotation.
- Use the work-energy theorem to determine magnitude of the angular velocity of the merry-go-round subsequent to the release of the merry-go-round by the person.

3) A uniform thin rod of mass 0.950 kg and length 1.20 m is mounted on a horizontal pin through the center of the rod at right angles to the rod such that the rod is free to spin in a vertical plane about the pin without friction. The rod is positioned horizontally at rest by a person who then releases the rod. The rod remains at rest until a ball of mass 0.265 kg is dropped on the rod from a height of 1.400 m above the rod. The ball hits the rod at a point between the center of the rod and one end of the rod. The collision of the ball with the rod is completely elastic. The ball bounces straight up to a maximum height of 0.599 m above the point of contact. How fast is the rod spinning after the ball hits the rod the first time but before the ball hits the rod again? (Note that the moment of inertia of a uniform thin rod, with respect to an axis that passes through the midpoint of the rod and is perpendicular to the rod, is given by $\frac{1}{12} m\ell^2$ where m is the mass of the rod and ℓ is the length of the rod.)

SAC124

Energy and Power

1) A marble of mass 17.0 g is fired straight upward from a spring-loaded gun. Initially, the marble, resting on top of the spring is 38.6 cm above the ground. The spring is ideal and massless. The force constant of the spring is 10.2 N/m. The spring is initially compressed 25.2 cm. The marble exits the gun just as the spring achieves its unstretched/uncompressed length.

- a) At what speed does the marble leave the gun?
- b) How high above the ground does the marble go? (Ignore air resistance.)

2) How much power does it take for an 82.0 kg person to run up stairs at a rate of 2.00 stairs per second given that each step of the stairs is 17.6 cm high?

3) How much energy must be supplied by the car's drive train, in joules, to keep a car going at 55 mph for one hour if it takes 25.0 horsepower (because of air resistance and rolling friction) to keep the car going at 55 mph?

4) A metal ball of mass 0.00500(50) kg has been dropped into a bottle of shampoo and is falling straight downward through the shampoo at a constant speed of 0.0527(20) m/s. The total depth of the shampoo in the bottle is 0.249(12) m. The bottle is located at an elevation of 246(5) m above sea level and the gravitational force constant at the location of the bottle is 9.8050(50) N/kg. What is the power of the metal ball? In other words: mechanical energy of the ball (actually, mechanical energy of the ball plus earth system), is decreasing at what rate? [Note that the notation 1.2700(50) m/s means the same thing as $(1.2700 \pm .0050)$ m/s, 246(5) m means the same thing as (246 ± 5) m, .0527(20) m/s means the same thing as $(.0527 \pm .0020)$ m/s, etc.]

Impulse and Momentum Problems

1) A baseball, having a mass of 0.14 kg arrives at a batter traveling horizontally with a speed of 45 m/s. The batter hits the ball in such a manner that the ball exactly reverses its direction of travel and leaves the bat with a speed of 55 m/s.

a) Determine the impulse delivered to the ball.

b) Suppose that the bat was in contact with the ball for 0.18 s. Determine the average force exerted on the ball by the bat while the ball was in contact with the bat.

2) A bullet of mass 0.040 kg is traveling at 220 m/s when it strikes a tree and comes to rest. Determine the impulse delivered to the bullet by the tree.

3) The head of a golf club exerts a force of 33 N on a ball of mass 0.050 kg for 0.097 s. The ball is initially at rest. Use the impulse/momentum relation to determine the velocity of the ball at the end of the 0.097 s time interval.

4) A non-spinning disk (disk 1) of mass 0.150 kg is sliding northwestward along a horizontal frictionless surface when it collides elastically with another disk (disk 2 of mass .120 kg) which was initially at rest. Assume the interaction between the disks is frictionless. Disk 1 delivers an impulse of 6.40 N·s westward to disk 2. Find the energy and the momentum (direction and magnitude) of disk 2 after the collision. (Westward means due westward.)

SAC126

Simple Harmonic Motion Problems

1) Consider an object of mass 0.24 kg, on a frictionless horizontal surface, on the end of a horizontal spring of spring constant 1800 N/m. The object is pulled to a point 15 cm from its equilibrium position, stretching the spring 15 cm, and, at time zero, released from rest.

- Determine the frequency of oscillation.
- Determine the period of oscillation.
- Write expressions for the position, velocity, and acceleration of the object, in terms of time.
- Determine the position, velocity, and acceleration at time 0.050 s.

2) Consider an object of mass 0.15 kg, on a frictionless horizontal surface, on the end of a horizontal spring. The position of the object expressed in terms of the time variable t , is:

$$x = 0.054\text{m} \cos\left(12 \frac{\text{rad}}{\text{s}} t\right)$$

- Determine the amplitude of the oscillations.
- Determine the Period of oscillation.
- Determine the frequency of oscillation.
- Determine the velocity of the object at time 0.10 s.
- Determine the spring constant.

3) An object of mass 0.550 kg hangs at rest from the end of a spring whose spring constant (force constant) is 21.5 N/m. An external agent lifts the object 0.200 m above its equilibrium position and releases it from rest.

- Find the time it takes, subsequent to the object's release, for the object to initially arrive at a position 0.100 m above its equilibrium position.
- Find the velocity and acceleration of the object at the time you found in part a.

4) The position, in terms of time, of a block of mass 0.20 kg on a frictionless horizontal surface, on the end of a horizontal spring which has a force constant of 1200 N/m, is

$$x = (0.044\text{m}) \cos(2\pi f t)$$

- Determine the total mechanical energy of the system.
- Determine the maximum velocity of the block.
- Determine the velocity of the block when $x = 0.022$ m.

5) The velocity of an object undergoing simple harmonic motion is $v = \left(14 \frac{\text{m}}{\text{s}}\right) \sin\left[\left(32 \frac{\text{rad}}{\text{s}}\right)t\right]$.

Find the frequency of oscillation. Express your answer in units of Hertz.

SAC127

The Simple Pendulum

- 1) Find the frequency of oscillations of a simple pendulum of length 9.00 m, at the surface of the earth.
- 2) How long must a simple pendulum be in order for it to have a period of 1.00 seconds?
- 3) Geologists use pendulums to find tiny differences in the earth's gravitational field from one position to another because these differences provide information on what is underground. A 1.0000 m simple pendulum is observed to have a period of 2.0083 s. Find the gravitational force constant, to 5 significant digits, at that location.
- 4) A person is making a graph of the effective length of a pendulum versus the measured length for a particular pendulum bob with a particular kind of string. She determines the effective length by measuring the time it takes for the pendulum to undergo 100 oscillations, and calculating the length of the ideal simple pendulum that would complete 100 oscillations in that amount of time. A geophysical company has informed her that their measurements show that the gravitational force constant at the location of her pendulum is $9.8060(52)$ N/kg. Her measured value for the time it takes her pendulum, at one particular length, to undergo 100 oscillations is 4 minutes 32.06(15) seconds. Find the effective length (and the uncertainty of the effective length) of the pendulum.

Wave Problems

- 1) Consider two long, taut, horizontal strings, side by side, identical in all respects, including tension. The end of one of the strings is caused to continually oscillate up and down with frequency f , thus causing a wave to travel along the length of the string, away from the oscillating end. Waves carry energy so energy is being transmitted along the length of the string. The end of the other string is caused to continually oscillate up and down at the same frequency f in such a manner that the rate at which energy passes through a given point of the string where the wave exists, is twice the rate at which energy passes through the corresponding point in the first string. (Consider the string to be so long that, during the time interval under investigation here, neither wave ever makes it to the other end of the string it is in.) **How does the amplitude of the wave in the second string compare with the amplitude of the wave in the first string?** [The amplitude in the second string is some factor times the amplitude in the first string. Calculate a value for that factor and write (with the blank filled in): “The amplitude in the second string is _____ times the amplitude in the first string.”]
- 2) What happens to the rate at which energy is being transferred along the length of a string due to a traveling wave in the string if the amplitude of the wave is doubled without changing the tension of the string or the frequency of the wave?
- 3) Find the speed of a wave traveling in a string when the frequency of oscillations of the oscillator that is causing the wave is 77.0 Hz and the wavelength is 0.650 m.
- 4) Find the speed of a wave traveling in a string whose linear mass density is 0.0360 kg/m when the tension in the string is 14.4 N.
- 5) Find the wavelength of a wave in a string of linear density 15.0 g/m and tension 9.70 N when the frequency of the wave is 66.0 Hz.
- 6) Find the speed (and the uncertainty of the speed) of a wave traveling in a string when the tension in the string is 3.000(72) N, the frequency of oscillations of the oscillator that is causing the wave is .2250(35) kHz and the wavelength is 0.1500(48) m.

Wave Problems

1. A wave on a string conforms to the equation

$$y = 0.156 \text{ m} \cos \left[\left(22.5 \frac{\text{rad}}{\text{m}} \right) x - \left(1444 \frac{\text{rad}}{\text{s}} \right) t \right]$$

- Consider a different system. In particular consider a ball of mass 111 g suspended from the end of an ideal spring. What would the spring constant have to be in order for the ball to oscillate with the frequency of the wave?
- What would the maximum kinetic energy of the ball in part a be if it were oscillating on the end of the spring in part a with the amplitude of oscillations being the same as the given wave amplitude?

2) A wave on a string of linear density 0.0032 kg/m is governed by the equation

$$y = 0.28\text{m} \cos \left[\left(7.0 \frac{\text{rad}}{\text{m}} \right) x - \left(58 \frac{\text{rad}}{\text{s}} \right) t \right]$$

- What is the wavelength of the wave?
- What is the period of the wave?
- What is the frequency of the wave?
- What is the wave speed?
- What is the tension in the string?
- What is the amplitude of the wave?

3) The tension in a string of linear density 0.0025 kg/m is 7.8 N. A mechanical oscillator attached to one end of the string oscillates at 94 Hz producing a wave in the string. The maximum displacement of any point on the string at any point in time is 0.31 m. Consider the positive direction for x to be away from the oscillator. (Assume the string to be so long that during the period of observations under consideration here, the wave produced by the mechanical oscillator does not make it to the other end of the string.)

- What is the wavelength of the wave?
- What is the period of the wave?
- What is the frequency of the wave?
- What is the wave speed?
- What is the amplitude of the wave?
- Write an expression giving the displacement of a point on the string in terms of both the position x of that point along the length of the string and the time t . Assume that at $(x = 0, t = 0)$ y takes on its maximum value.

SAC130

Sound Intensity and Loudness Problems

- 1) What intensity of sound is required to produce an intensity level of 90.0 dB? (The sound intensity at the threshold of human hearing, I_0 , is $1.00 \times 10^{-12} \frac{\text{W}}{\text{m}^2}$.)
- 2) How does the intensity level (loudness) of sound change if the intensity of the sound is doubled.
- 3) How must the intensity of sound change in order to increase the loudness by 20.0 dB?
- 4) The intensity of sound at a specific location is $2.56 \times 10^{-9} \frac{\text{W}}{\text{m}^2}$. What is the loudness (intensity level) of the sound at that location? Express your answer in decibels.

SAC131

Strings and Air Columns

- 1) Find the wavelength of the sound wave produced in air by the vibrating segment of a guitar string whose length is 0.440 meters and whose linear density is 2.01 grams/meter, in which the tension is 26.7 N, and in which only the first harmonic is present. Assume the speed of sound in air to be 343 m/s.
- 2) Consider a tube of length 0.642 m which is closed at one end and open at the other end. Make a sketch of displacement vs. position along the length of the tube for standing waves corresponding to the fundamental frequency and the first overtone. Working from your second sketch, determine the wavelength of the first overtone. If the speed of sound in air is 343 m/s, determine the frequency of the first overtone. Which harmonic is the first overtone?
- 3) How long does a tube that is closed at both ends have to be so that its first harmonic (actually the first harmonic of the air column within the tube) is a B^b (B-flat) corresponding to a frequency of 466 Hz at a time when the speed of sound in air is 343 m/s?
- 4) A person takes the data needed to determine the frequency of oscillations of a mechanical oscillator attached to one end of a horizontal piece of string as follows: First she ties one end of the string to a vertical rod and arranges the string so that it extends horizontally to a pulley, passes over the pulley and extends downward to an object on which the earth's gravitational force is 65.000 N. (She chooses this weight based on previous trials.) She makes two marks, 1.350(2) m apart from each other on the string. She removes the string from the device and cuts the string at each mark so that she has a piece of string that, when it has a tension of 65.000 N, has a length of 1.350(2) m. She measures the mass of the string and finds it to be 4.022(2) g. Now she ties one end of that piece of string to the part of the mechanical oscillator that oscillates when the mechanical oscillator is energized. She extends the string horizontally to a pulley, over the pulley and downward to a slotted disk holder. She gets three maximal antinodes with an object (the holder with some slotted metal disks on it) on which the earth's gravitational force is 65.020(50) N, hanging from the end of the string with the mechanical oscillator energized. She measures the distance between the two interior nodes and finds it to be 0.295(7) m. What is the frequency of oscillations (and the uncertainty of the frequency of oscillations) of the mechanical oscillator?
- 5) a) Determine the wavelength of the third harmonic for a string of length 1.00 m which is fixed at both ends. Include sketches of a snapshot of the string undergoing the standing wave motion associated with the first, second, and third harmonic as part of your solution (3 sketches). Make sure your solution is consistent with your third sketch.
b) Suppose that the mass of the 1.00 m length of string is 4.60 g and that the tension in the string is 1.25 N. Determine the frequency of the third harmonic.
- 6) How tightly must a guitar string of linear mass density 3.45(15) g/m be strung for its fundamental frequency to be 110 Hz (the frequency of the note A) when the fixed ends of the string are .668(45) m apart from each other? *(Some of the values provided in this question came from Table 4.8 Measured Properties of Guitar Strings in the book Acoustics for Violin and Guitar Makers by Erik Jansson of the Speech, Music and Hearing part of the Department of the School of Computer Science and Communication of the Kungl Tekniska Högskolan, Sweden. At the time of this writing, the book was available online in pdf (portable document format) at <http://www.speech.kth.se/music/acviguit4/> .*

SAC132

Beats and the Doppler Effect Problems

- 1) Two sound sources each producing waves of one and the same audible amplitude are in one and the same room. One of the sound sources is producing waves at a frequency of 177.2 hertz while the other is producing waves at a frequency of 182.5 hertz. Find the beat frequency that would be heard by a person in the room.
- 2) Two sound sources are producing waves of about the same amplitude in a room. The speed of sound in the air in the room is 343 m/s. A beat frequency of 2.80 Hz is heard by a person standing in the room in the vicinity of the two sources. One of the sources is known to be producing sound whose wavelength in air is 53.0 cm. The other is producing sound of a shorter wavelength. What is the value of this shorter wavelength?
- 3) A 331 Hz oscillator is traveling at 45.0 m/s toward a person who is standing at rest. The speed of sound in air is 343 m/s. What is the frequency of the sound heard by the person?
- 4) A car is driving at a speed of 32 m/s directly away from a person that is standing in the road. The driver is sounding the horn. The horn oscillates at a steady frequency. The person that is standing in the road hears a frequency of 222 Hz. With what frequency is the horn oscillating? Use 343.0 m/s as the speed of sound in air.
- 5) A receiver is moving toward a stationary sound source in air. The source is producing sound waves with a wavelength of 0.950 m. The received frequency of the waves is 475 Hz. How fast is the receiver moving relative to the air?
- 6) What must the speed of sound (and its uncertainty) in air be on an occasion when the frequency measured by an observer is 470.00(11) Hz while the observer is moving at a speed of 21.26(15) m/s directly away from a stationary 501.00(12) Hz sound source?

SAC133

Archimedes' Principle Problems

- 1) A boat of mass 4200 kg floats at rest on fresh water.
 - a) Determine the buoyant force exerted on the boat by the water.
 - b) Determine the volume of water displaced by the boat.

- 2) A rock of mass 110 g and density $2.8 \frac{\text{g}}{\text{cm}^3}$ is suspended by a string in a container of water. The rock is totally submerged and is not in contact with the container. Find the tension in the string.

- 3) A rock of mass 47 g and density $2.3 \frac{\text{g}}{\text{cm}^3}$ rests on a cork of mass 25 g and density $0.25 \frac{\text{g}}{\text{cm}^3}$ in a bucket containing 12 liters of water (1 liter is $1 \times 10^{-3} \text{ m}^3$) in the shape of a right circular cylinder of diameter 29 cm. (This is the shape assumed by the water because it is the shape of the bucket interior). Someone knocks the rock off the cork. The rock falls to the bottom of the bucket where it comes to rest. The cork remains floating on the surface. Does the water level change? If so which way and by how much.

- 4) A person of mass 57 kg finds that if she has her lungs full of air that she can float in fresh water but that if she exhales most of the air out of her lungs she sinks. Such a person is justified in estimating her average density to be about the same as the density of water. Based on the assumption that her average density is that of water, what is the buoyant force exerted upon her by the air when she is standing in your classroom. Assume that the density of the air in the classroom is 1.29 kg/m^3 and that the pressure of the air in the room is 101.3 kN/m^2 .

- 5) (Use a numerical method to solve this one.) A rubber ball of mass 8.488 g and diameter 2.587 cm is repeatedly released from the bottom of a bucket that is filled to a depth of 32.70 cm with fresh water. For each trial, the time from the instant the ball is released from a position where it is just touching the bottom of the bucket to the instant the top of the ball arrives at the surface, is measured. The data conforms to a Gaussian distribution with a mean value of 2.38 s. Assuming that, in addition to the other forces acting on the ball, there is a viscous force directed in the direction opposite that of the velocity of the ball, with a magnitude given by $F_v = c v$ where v is the speed of the ball and c is a constant; find the value of c . (Show all work. Include a printout of the first page of the spreadsheet with graphs.)

SAC134

Pascal's Principle and Fluid Flow Problems

- 1) A car of mass 826 kg is being lifted at a constant speed by means of a hydraulic lift. The car is on top of a piston of mass 17.0 kg. The face of the piston, that part of the piston that is in direct contact with the hydraulic fluid, is a circle of radius 25.4 cm. Find the pressure of the hydraulic fluid.
- 2) A vertical pipe, closed at both ends of has a column of water in it which is 10.2 m long. The pipe is a bit longer than that. Inside the pipe, above the water, is a very short column of air at atmospheric pressure. A boy drills a hole in the top end of a pipe and affixes a tire valve to the top end of the pipe. Then he uses a bicycle pump to pump air into the top end of the pipe. He does so until the gauge pressure in the top end of the pipe is 414 kPa. What is the absolute pressure in the water at the lowest point in the pipe. (Gauge pressure is the pressure minus atmospheric pressure. Absolute pressure is pressure. The adjective "absolute" is used to emphasize the fact that the pressure in question is not a gauge pressure.)
- 3) Water passes through a 0.63 cm diameter kitchen faucet at a rate of 7.5 liters per minute in a house supplied with water via a 2.5 cm diameter horizontal pipe which is 4.5 m below the level of the faucet. The pressure of the water in the faucet is 93000 Pa.
 - a) What is the velocity of the water in the faucet?
 - b) What is the flow rate of the water in the supply pipe?
 - c) What is the velocity of the water in the supply pipe?
 - d) What is the pressure of the water in the supply pipe?
- 4) Fluid flowing through a pipe completely fills the pipe. The fluid is non-viscous and incompressible and the flow is streamline and steady state. The cross-sectional area of the pipe at one point is 95 cm^2 and the fluid velocity at that point is 8.9 m/s. At another point in the pipe the cross-sectional area of the pipe is only 25 cm^2 . Determine the fluid velocity at this point in the pipe.
- 5) A horizontal pipe has a diameter of 5.00 cm along one part of its length and a diameter of 2.80 cm along another part of its length. The pipe is completely full of water flowing from the wide part to, and through, the narrow part. The flow is to be considered steady state, streamline, and non-viscous. In the wide part of the pipe, the pressure of the water is $1.60 \times 10^5 \text{ Pa}$ and the speed of the water is 1.20 m/s. Find the pressure of the water in the narrow part of the pipe.

SAC135

1) How much energy in the form of heat must flow into 2.00 liters of liquid water at 25.0°C to increase the temperature of the water to the boiling point, 100.0°C ?

2) A 210 g piece of solid copper at 99°C is combined with 180 g of mercury at 25°C. Determine the equilibrium temperature of the system. (Assume that no energy is exchanged with the surroundings.) The specific heat of copper is $390 \frac{\text{J}}{\text{kg} \cdot \text{C}^\circ}$ and the specific heat of mercury is

$$140 \frac{\text{J}}{\text{kg} \cdot \text{C}^\circ}.$$

3) A 100.0°C solid cube of copper, 2.54 cm on a side, is placed in 99.9 g of liquid water at 25.0°C. The system is at atmospheric pressure and remains at atmospheric pressure but is thermally isolated from the surroundings. Find the final, temperature of the water.

4) A brass object has essentially the shape of a right circular cylinder of length 6.8 cm and diameter 4.8 cm. The object has a mass of 1.000 kg. The density of the kind of brass of which the object is made is 8650 kg/m^3 and the specific heat capacity of the kind of brass of which the object is made is $377 \frac{\text{J}}{\text{kg} \cdot \text{C}^\circ}$. Complete the following table:

a) Energy Q that would have to flow into the rod in the form of heat to increase the temperature of the rod 2.00 C°	
b) Distance h that one would have to lift the rod to do an amount of work on the rod equal to the amount of energy in item a.	
c) Speed v that the object would have to have in order for its kinetic energy of translation to be equal to the amount of energy found in a.	

SAC136

Phase Change Problems

1) Approximately how much heat would it take to change .130 kg of ice (solid water) at -12.0°C to water vapor (water in gaseous form) at 112.0°C ? (Assume that no energy is exchanged with the surroundings.) Use:

$$\text{Specific Heat of Ice: } 2.09 \frac{\text{kJ}}{\text{kg} \cdot \text{C}^{\circ}}$$

$$\text{Specific Heat of Liquid Water: } 4.186 \frac{\text{kJ}}{\text{kg} \cdot \text{C}^{\circ}}$$

$$\text{Specific Heat of Water Vapor: } 2.01 \frac{\text{kJ}}{\text{kg} \cdot \text{C}^{\circ}}$$

$$\text{Water's latent heat of fusion is } 334 \frac{\text{kJ}}{\text{kg}}.$$

$$\text{Water's latent heat of vaporization is } 2.26 \times 10^3 \frac{\text{kJ}}{\text{kg}}$$

2) A 467 gram chunk of solid water (ice) at -12.5°C is put into a Styrofoam bucket which has some liquid water at 24.0°C in it. A lid is put on the bucket. The heat capacity of the bucket is negligible as is the heat capacity of the air trapped in the bucket. Heat flow into or out of the water from or to the surroundings is negligible. When equilibrium is reached, the bucket is found to contain only liquid water at 1.2°C . At that point, how much water, by mass, is in the bucket? (Assume that the entire process takes place at atmospheric pressure.)

3) An ice cube of mass 0.250 kg at a temperature of -5.0°C is combined with 0.500 kg of liquid water at 45.0°C (Assume that no energy is exchanged with the surroundings. Use the values from problem 1.)

a) What is the equilibrium temperature?

b) At equilibrium, what is the mass of the water in solid form and what is the mass of the water in liquid form?

4) At atmospheric pressure, how much heat does it take to convert 2.50 kg of ice (solid water) at -15.0°C to liquid water at 25.0°C ?

5) At atmospheric pressure, how much heat does it take to convert 0.76 kg of liquid water at 23.0°C to water vapor at 125.0°C ?

6) A solid single-substance object of mass m has a heat capacity (not a specific heat capacity but an actual heat capacity) C . The object is at room temperature T_o . It melts at a higher temperature T_m . Starting with the object at room temperature, a person has to cause an amount of heat Q to flow into the object to convert it completely to liquid at its melting temperature. Find the latent heat of fusion of the material of which object is made.

The First Law of Thermodynamics Problems

- 1) 35.0 joules of heat is caused to flow into a gas in a cylinder fitted with a vertical frictionless piston of mass 0.450 kg whose face is in contact with the upper surface of the gas. The cylinder-plus-piston arrangement is situated in vacuum. The internal energy of the gas increases by 15.0 joules. The process occurs so slowly that the kinetic energy of the piston is at all times negligible—the piston is to be considered at rest at the end of the process. Find the distance that the piston is lifted.
- 2) A cannon fires a cannonball of mass 23.0 kg. The burning of the gunpowder quickly produces a hot gas with a total internal energy of 246 kJ prior to any detectable motion of the cannon ball. The gases then expand as the force resulting from the pressure of the gas accelerates the cannonball along the barrel. The internal energy of the gas just as the ball exits the barrel is only 114 kJ despite the fact that the expansion occurs so rapidly that no heat flows out of the gases during the expansion. Find the muzzle velocity of the cannonball.
- 3) A rubber band acts like a spring with a force constant of 50.0 N/m and an unstretched length of 7.00 cm. The mass of the rubber band is 0.500 g and the specific heat of the rubber it is made of is $2690 \frac{\text{J}}{\text{kg} \cdot \text{C}^\circ}$. A person stretches the rubber band by holding one end fixed and pulling the other end away from the fixed end until the length of the rubber band is 30.0 cm. Starting with the rubber band in this configuration, find the temperature change experienced by the rubber band when the person holding the rubber band, while maintaining the fixed end in a fixed position, moves the other end to a position 7.00 cm from the fixed end. Assume that the change in configuration occurs so quickly that no heat flows into or out of the rubber band in the process.

Linear Motion Problem for Classical Physics

1) A toy manufacturer comes out with a magnetic levitation train. Relative to a start line, with forward being the positive direction, the train is observed to move along a straight track section such that its position is given by:

$$x = (0.52 \frac{\text{m}}{\text{s}^2})t^2 - (0.52 \frac{\text{m}}{\text{s}^4})t^4$$

where x represents position and t represents the amount of time that has elapsed since the start of the observations on the motion of the train; m and s are the units meters and seconds respectively. Note that the acceleration of the train is not constant.

- a) Find the position of the train at time $t = 1.0$ seconds.
- b) Express the velocity of the train in terms of time.
- c) Find the velocity of the train at time $t = 1.0$ seconds.
- d) Is the train going forward, or is it going backward at time $t = 1.0$ seconds?
- e) Express the acceleration of the train in terms of time.
- f) Find the acceleration of the train at time $t = 1.0$ seconds.
- g) At time $t = 1.0$ seconds, which of the following best characterizes the motion of the train:
 - i. It is going forward at an increasing speed.
 - ii. It is going forward at a constant speed.
 - iii. It is going forward at a decreasing speed.
 - iv. It is going backward at an increasing speed.
 - v. It is going backward at a constant speed.
 - vi. It is going backward at a decreasing speed.

SAC308

1) An object's position is given in terms of time as:

$$x = (4.0 \text{ m}) + \left(15 \frac{\text{m}}{\text{s}}\right)t - \left(6.5 \frac{\text{m}}{\text{s}^2}\right)t^2$$

- a) Use calculus to determine the time, after time 0, at which x is a maximum.
- b) Substitute the time found in part a into the given equation to find the maximum value of x .
- c) Find the time (greater than 0) at which $x = 0$.
- d) Make a graph of x vs. t for values of time t between 0 and that time (greater than 0) at which x is 0.

SAC309

- 1) What is the speed of a particle whose velocity is $6.5 \frac{\text{m}}{\text{s}} \hat{i} + 5.9 \frac{\text{m}}{\text{s}} \hat{j} + 1.2 \frac{\text{m}}{\text{s}} \hat{k}$?
- 2) Given that $\vec{C} = \vec{A} + \vec{B}$ where $\vec{A} = 27.1\text{m}\hat{i} + 15.5\text{m}\hat{j} - 38.2\text{m}\hat{k}$ and $\vec{B} = 18.5\text{m}\hat{i} + 18.5\text{m}\hat{j} - 14.6\text{m}\hat{k}$, find \vec{C} . Note that the “m” in the expressions for \vec{A} and \vec{B} represents the unit, the meter.
- 3) Given that $\vec{a} = \vec{a}_1 + \vec{a}_2$ where $\vec{a} = 1.2 \frac{\text{m}}{\text{s}^2} \hat{i} + 3.5 \frac{\text{m}}{\text{s}^2} \hat{j}$ and $\vec{a}_1 = 5.0 \frac{\text{m}}{\text{s}^2} \hat{i} - 2.4 \frac{\text{m}}{\text{s}^2} \hat{j} + 1.8 \frac{\text{m}}{\text{s}^2} \hat{k}$, find \vec{a}_2 .

SAC317

1) The angular position of a rotating object in terms of time is given as:

$$\theta = .250\text{rad} + .0140\frac{\text{rad}}{\text{s}^2}t^2 + .0880\frac{\text{rad}}{\text{s}^4}t^4$$

- Find the angular velocity of the object in terms of time.
- Find the angular acceleration of the object in terms of time.
- Find the angular position of the object at time $t = 1.2$ s.
- Find the angular velocity of the object at time $t = 1.2$ s.
- Find the angular acceleration of the object at time $t = 1.2$ s.

2) The angular position of a rotor for the first 1.25 s of its motion is given by

$$\theta = 42.0\frac{\text{rad}}{\text{s}^2}t^2 - 11.2\frac{\text{rad}}{\text{s}^3}t^3 .$$

After that, the rotor spins at a constant rate equal to the angular velocity of the rotor at the end of the first 1.25 s of its motion. Once it is spinning at that constant rate, how long does it take for the rotor to complete one revolution?

3) The angular velocity of a spinning object, in terms of time, is given by:

$$\omega = 18.0\frac{\text{rad}}{\text{s}} - 3.00\frac{\text{rad}}{\text{s}^2}t + 0.250\frac{\text{rad}}{\text{s}^3}t^2$$

Find the angular acceleration of the object at $t = 5.00$ s.

SAC318

1) Find the cross product, $\vec{A} \times \vec{B}$, of the following two vectors:

$$\vec{A} = 4.0\hat{i} - 3.5\hat{j} + 2.4\hat{k}$$

$$\vec{B} = 1.4\hat{i} + 2.0\hat{j} - 5.0\hat{k}$$

2) Use your result from problem 1, and the fact that the magnitude of $\vec{A} \times \vec{B}$ is $AB \sin \theta$ to determine the angle between the vectors \vec{A} and \vec{B} given in problem 1 above.

3) Two pipe segments are welded together to form an “L”. Refer to the diagram at right. The 0.250 m segment lies on the z-axis with one end at the origin as shown. The 0.560 m segment is parallel to the y-axis. Find the torque about the origin resulting from the force \vec{F} acting on the top of the “L.”

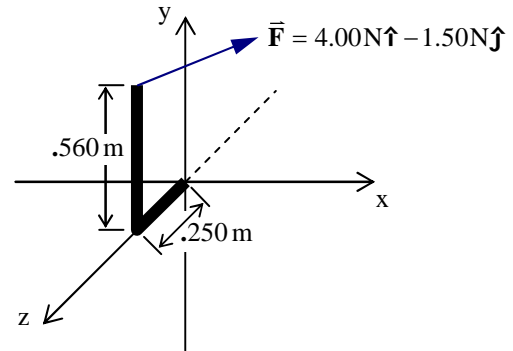

4) Find the magnitude of the torque (and the uncertainty of the magnitude of the torque), relative to the origin of the coordinate system for which the one force acting on the object in question can be expressed as

$$\vec{F} = (14.00 \pm .85)\text{N}\hat{i} + (-3.27 \pm .32)\text{N}\hat{j} + (21.50 \pm 1.05)\text{N}\hat{k}$$

and the position vector for the point of application of the force can be expressed as

$$\vec{r} = (-.850 \pm .045)\text{m}\hat{i} + (-.750 \pm .035)\text{m}\hat{j} + (.260 \pm .016)\text{m}\hat{k}.$$

SAC321

1) Consider an origin at point A and three tiny objects, all at one and the same elevation.

Object #1 of mass 4.5 kg is .35 m north of A.

Object #2 of mass 8.0 kg is .50 m east of A.

Object #3 of mass 4.5 kg is .42 m southwest of A.

Find the position of center of mass of the system of masses with respect to the origin at point A.

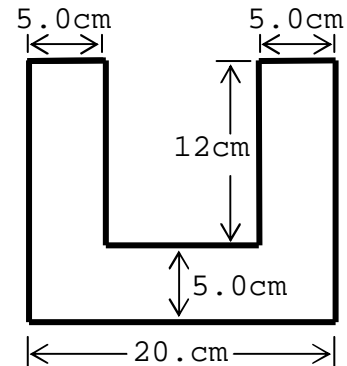

2) Find the center of mass of the U-shaped uniform plate depicted at right.

3) Find the center of mass of a uniform plate in the shape of a right triangle of base .30 m and height .15 m.

4) The moment of inertia of a uniform disk of mass m and radius r with respect to an axis perpendicular to the face of the disk that extends through the center of the disk is $\frac{1}{2}mr^2$.

Find the moment of inertia of a uniform disk of mass m and radius r with respect to an axis perpendicular to the face of the disk that extends through the rim of the disk.

5) The moment of inertia of a uniform thin rod of mass m and length l , with respect to an axis that is perpendicular to the rod and passes through the center of the rod, is $\frac{1}{12}ml^2$. The moment of inertia of a uniform sphere of mass m and radius r , with respect to an axis through its center, is $\frac{2}{5}mr^2$. A pendulum consists of a thin uniform vertical rod of mass .50 kg and length .50 m and a uniform sphere of mass .45 kg and radius .25 m. The bottom end of the rod is attached to the top surface of the sphere. Where they meet, the rod is perpendicular to the surface of the sphere. The pendulum is pinned so that it is free to rotate about a horizontal axis that passes through the rod at a point 0.10 m below the upper end of the rod. Find the moment of inertia of the pendulum with respect to the axis of rotation just described.

6) Three identical uniform rectangles of sheet metal lie in one and the same horizontal plane. Each piece has mass m , length l , and width w where $w < l$. Two of the pieces abut the third piece at either end of the third piece in such a manner as to form a symmetric letter I. Find the moment of inertia of the letter "I" thus formed about a vertical axis through the center of the "I". (Use the fact that the moment of inertia of a uniform thin rectangular plate of mass m , length l , and width w , about an axis perpendicular to the plate through its center, is $\frac{1}{12}m(l^2 + w^2)$.)

SAC323

1) The potential energy of a particle, in terms of its Cartesian coordinates (x, y, z) , is given by

$$U = -\frac{Gm_1m_2}{\sqrt{x^2 + y^2 + z^2}}$$
 where G , m_1 , and m_2 are constants. Find the y-component of the force

(that force which is characterized by the potential energy function) on the particle, expressed in terms of the particle's Cartesian coordinates.

Energy and Power Problems

- 1) The total amount of energy delivered to the wheels of a car from time 0 to time t is given in terms of the time t by:

$$E = \left(35.0 \frac{\text{J}}{\text{s}}\right)t + \left(1.5 \frac{\text{J}}{\text{s}^2}\right)t^2$$

in which the “J” and the “s” are the units Joules and seconds respectively.

- Find the power delivered to the wheels, in terms of the time t .
 - Evaluate your answer to part a to determine the power to the wheels at time $t = 2.4 \text{ s}$.
- 2) In milling a part out of a solid block of steel, starting with the first contact of the bit with the steel, the amount of energy used by the milling machine, in terms of time, is given by:

$$E = 5490 \text{ J} \left(1 - e^{-t/(9.25 \text{ s})}\right)$$

in which the “J” and the “s” are the units joules and seconds respectively. Find the power being used by the milling machine at 18.0 s after first contact.

- 3) The kinetic energy K of an object, in terms of time t , is given by

$$K = 7.80 \text{ J} \left(1 - \frac{1.00 \text{ s}^2}{(t + 1.00 \text{ s})^2}\right)$$

in which the J is the unit of energy, the joule, and the s is the unit of time, the second. Find the power, expressed in terms of time, that would cause the kinetic energy to vary with time in such a manner.

SAC326

1) Prove that $x = A\cos(2\pi ft)$ with $f = \frac{1}{2\pi}\sqrt{\frac{k}{m}}$ is a solution to the simple harmonic motion equation $-kx = m\frac{d^2x}{dt^2}$. (Hint: Substitute the proposed solution into the equation and show that it leads to an identity. Note that an identity is a trivial equation, such as $2 = 2$ or $b = b$, which is obviously true.)

SAC 329

1) Prove that $y = y_{\max} \cos\left(\frac{2\pi}{\lambda}x - \frac{2\pi}{T}t\right)$ is a solution to the wave equation $\frac{\partial^2 y}{\partial x^2} = \frac{1}{v^2} \frac{\partial^2 y}{\partial t^2}$ with

the wave velocity being related to the wavelength and period by $v = \frac{\lambda}{T}$. (Hint: Substitute the

proposed solution into the equation and show that it leads to an identity. Note that the derivatives are partial derivatives and hence; when you take the derivative with respect to x , you should treat t as a constant; and; when you take the derivative with respect to t , you should treat x as a constant. Further note that an “identity” is a trivial equation such as $3 = 3$ or $b = b$ whose correctness is self-evident.)